

A UNIT OF DATAMARINE INTERNATIONAL[®]

AMERICAN TECHNOLOGY THAT TALKS TO THE WORLD

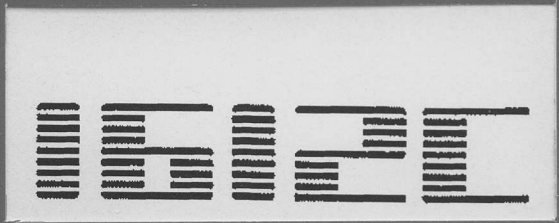



SEA 1612C / 1612W / 1612WX

AUTOMATIC ANTENNA TUNER

INSTRUCTION AND MAINTENANCE MANUAL

© Copyright 1993, 1994 SEA Inc.
All rights reserved.

SEA Inc.
7030 220th St. S.W.
Mountlake Terrace, Washington 98043

(425) 771-2182
FAX: (425) 771-2650

MAN-1612C
Revision D
July 2001



IMPORTANT

NOTICE TO INSTALLERS

The 1612C is designed to be weatherproof when properly installed. Be sure all fasteners are tight and cable entries sealed. No warranty claims will be allowed for water damage to the contents.

TABLE OF CONTENTS

	PAGE
1. GENERAL INFORMATION.....	1 - 1
1.1 Overall Description.....	1 - 1
1.2 Electrical Configuration.....	1 - 2
1.3 Mechanical Configuration.....	1 - 2
1.4 Weather Housing.....	1 - 4
2. SPECIFICATIONS AND PARTS FURNISHED.....	2 - 1
2.1 Specifications.....	2 - 1
2.2 Parts Furnished.....	2 - 2
3. PRINCIPLE OF OPERATION.....	3 - 1
3.1 Networks.....	3 - 1
3.2 Schematic Diagrams.....	3 - 1
3.3 Auto Tune Operation.....	3 - 1
3.4 Vswr Detector.....	3 - 3
3.5 Frequency Counter.....	3 - 3
3.6 Phase Detector.....	3 - 4
3.7 The Control Computer.....	3 - 4
3.8 Initialization And Fireup.....	3 - 4
3.9 Information Read.....	3 - 5
3.10 Information Write.....	3 - 5
3.11 The Program.....	3 - 5
4. INSTALLATION PROCEDURE.....	4 - 1
4.1 Mechanical Considerations.....	4 - 1
4.2 Electrical Considerations.....	4 - 2
4.3 Electrical Checkout.....	4 - 3
5. TROUBLESHOOTING.....	5 - 1
5.1 COUPLER WILL NOT TUNE - NO RELAY ACTION.....	5 - 1
5.2 RELAYS OPERATE BUT NO TUNE.....	5 - 2
5.3 COUPLER TUNES BUT NO MEMORY.....	5 - 3
5.4 TUNER WILL NOT DEMAND TUNE.....	5 - 3
6. SCHEMATIC AND CIRCUIT BOARD LAYOUT	
7. SEA 1612C COMPONENT PARTS LIST	

LIST OF FIGURES

FIG. #	FIGURE NAME	PAGE
1.3	Outline and Mounting Dimensions.....	1 - 3
3.1	Network Configurations	3 - 2
6.1	Antenna Tuner Schematic (ASY-1616-01)	
6.2	Circuit Board Layout	

1. GENERAL INFORMATION

1.1 OVERALL DESCRIPTION

The SEA 1612C is a fully automatic antenna tuning unit, designed for the MF-HF spectrum and compatible with a wide variety of antenna systems. This product features an advanced microprocessor-based tuning algorithm which allows it to tune up on normal voice signals from the associated transmitter and also includes a "learning" algorithm which allows the control computer to remember which network constants are required for a given operating frequency. The memory feature permits the antenna tuner, once the "learning" operation is completed, to retune a given frequency in approximately 20 milliseconds. This is less than the time required to say "hello". Antenna tuner operation is completely automatic and requires no operator intervention. If the antenna system is altered or replaced, the tuner will automatically "relearn" the required networks. During the learning period, operation is somewhat slower and, depending on the particular frequency/antenna combination, up to 5 seconds may be required to achieve a matched condition. When the antenna has been properly matched, the tuner signals this condition by pulling a control line low. The control signal may be used to operate an "all tuned" indicator at the operators' T-R position. Such an indicator is provided in the SEA 222, SEA 322 and SEA 225 radiotelephones.

The SEA 1612C also includes a "DEMAND TUNE" function and a "TUNE LOCKOUT" capability.

The "DEMAND TUNE" function allows the user to force the antenna tuner to retune on demand. This permits "overwriting" previously stored tuneup information when desired.

The "TUNE LOCKOUT" feature is useful when two or more transmitters are co-located, or when it is desirable to inhibit the AUTO TUNE function for any reason.

E.G.: When two antennas are in close proximity, it is possible that transmitting on one antenna may cause considerable RF to be coupled into the adjacent antenna. This can cause the tuner to reset, disturbing the operation of the radiotelephone. In such cases, the "TUNE LOCKOUT" feature of the SEA 1612C can be used to prevent the SEA 1612C from entering the tune mode until the radiotelephone it is associated with is actually transmitting.

1.2 ELECTRICAL CONFIGURATION

The SEA 1612C matches the complex impedance of the antenna system to a nominal 50 ohms by selecting the proper network from a possible combination of 64 values of input C, 32 values of output C and 512 values of series L. Network configuration is automatically determined during the tune cycle and may be either a PI network or either of two types of L network. Whenever possible, the L network will be selected for maximum efficiency. Tuneup is entirely automatic and may be accomplished on voice signals, making it unnecessary to provide a "low power tune" mode in the transmitter.

The various RF sensors in the SEA 1612C are designed to function down to power levels of 10 to 20 watts. This feature makes the SEA 1612C compatible with radio equipment such as the SEA 225 which is equipped with circuitry to reduce the output power level in the presence of high VSWR.

1.3 MECHANICAL CONFIGURATION

All of the circuitry of the SEA 1612C is contained on printed circuit board PCB-1616-01. This printed circuit board is mounted on an aluminum shield plate with six 6-32 stainless steel screws. The shield plate is held in the molded weather housing with four 10-24 stainless steel screws. (Figure 1.3 shows the outline and mounting dimensions of the molded weather housing.)

The printed circuit board is solder-masked which helps to prevent corrosion and moisture problems.

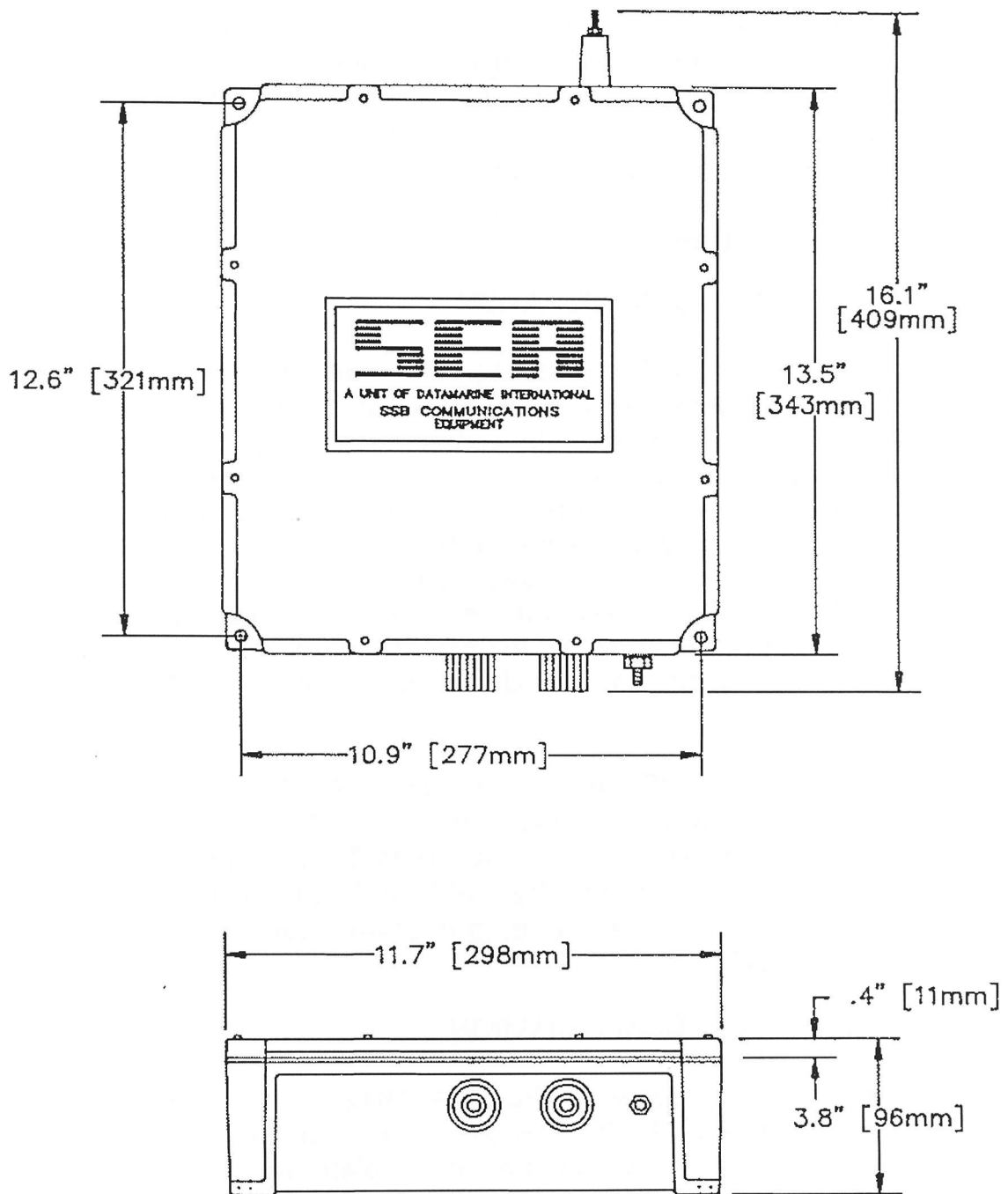

**SEA 1612C ANTENNA TUNER
OUTLINE & MOUNTING DIMENSIONS
FIGURE 1.3**

Both the SO-239 RF connector and the six pin interface connector strip are mounted on the printed circuit board itself. The interface connector accepts wire ends directly, eliminating any requirement for special lugs or lugging tools. A PL-259 type RF plug must be fitted to the coaxial feed line.

1.4 WEATHER HOUSING

The SEA 1612C antenna tuner is housed in a weatherproof molded case designed to withstand the environmental conditions encountered aboard ship when mounted on the weather decks. The internal construction is designed to withstand the shock and vibration of marine service. Corrosion-resistant hardware and passivated alloys are employed throughout.

Stuffing glands for the RF and DC cables are provided on the lower edge of the weather housing, along with a 1/4-20 stainless steel ground stud. The antenna connects to the ceramic insulator on the top of the weather housing.

1.5 SPECIAL MODELS OF THE 1612C

The 1612C is available in the following two optional configurations: the 1612W and the 1612WX. The 1612W is a 1612C with a gas filled spark gap tube installed on the printed circuit board assembly. This part will shunt excessively high voltages to the ground plane (near lightning strikes) to prevent damage to the RF sensors. The 1612WX is a 1612W with a RF relay assembly that shorts the antenna output connector to ground when then power to the coupler is switched OFF. Please contact the factory for additional information.

2. SPECIFICATIONS AND PARTS FURNISHED

2.1 SPECIFICATIONS

Frequency Range	1.6 to 30.0 MHz
RF Power Capability (PEP)	150 watts Peak Envelope Power
Input Impedance	50 ohms
VSWR	<2:1
Power Requirements	13.6 VDC negative ground
Operating Current	2 Amps max.
Tuning Time	"Learn Mode", typically less than 5 seconds "Educated Mode", approximately 20 milliseconds
Recommended Antenna Length	23-75 ft. (7-23 meters) 1.6-30 MHz 9 ft. (2.7 meters) whip 3-30 MHz
Mounting	Any position
Environmental Temp. Range	-30°C to +60°C
Size	in: 15 X 12 X 3.9 mm: 381 X 304.8 X 99
Weight	10 lbs./4.5 kgs.
Case Construction	Molded Weatherproof
Control Cable	No. 20 Gauge, 3 to 5 conductors, shielded (not supplied)

2.2 PARTS FURNISHED

1. Antenna Tuner with Cover and Bushings
2. Instruction Manual

3. PRINCIPLE OF OPERATION

3.1 NETWORKS

Figure 3.1 shows the schematic diagram for the two basic network configurations. Note that the "L" network as viewed from the generator may be configured as either "C in" or "C out", whichever is required by the load. In either case, the end of the network containing the shunt C element will be the HIGHER impedance end of the network.

3.2 SCHEMATIC DIAGRAMS

Figure 6.1 is the schematic diagram of the antenna tuner. RF input is applied to UHF fitting J1, 13.6 VDC is connected to the terminals marked GND and + on P1 (Pins 1 and 2 respectively), and an appropriate antenna and ground system are connected to feedthrough insulator and stainless steel stud respectively. The "TND" flag line (Pin 4 on P1) is connected to the remote indicator device used. When the SEA 1612C is used with the SEA 222, SEA 322 or SEA 225 radiotelephone, the flag line is connected to the "TND" line on the radio's rear panel connector.

3.3 AUTO TUNE OPERATION

When RF power is applied to the SEA 1612C it is first passed through an array of detectors which determine the frequency, load VSWR and the reactance sign. Forward power is continuously monitored, since the control computer requires an indication of both forward and reflected power in order to allow tuning to proceed. In practice, the forward power detector is used by the computer as a truth check to insure that the measurements made are indeed a result of applied RF and not spurious levels from the data conversion system. Tuneup will ONLY proceed when sufficient forward power is present to provide this truth check. After passing through the detector system, the RF is applied to the tuner array. This consists of 6 capacitors in shunt on the input arm of the network, arranged in binary increments, 9 inductors in the series arm, arranged in binary increments, and 5 more capacitors in shunt on the output arm, also arranged in binary increments. Relays are provided in conjunction with each

lumped constant which allow removal or entry as desired. Thus, it is possible through the manipulation of 26 relays to build a network having 64 values of input shunt C, 32 values of output shunt C, and up to 512 values of series L.

3.4 VSWR DETECTOR

Current transformer T1 and voltage transformer T2, in conjunction with termination resistors R1 and R5 make up a dual directional coupler. This directional coupler is inserted in the 50 ohm transmission line between the input connector, J1, and the tuning network. A sample of FORWARD power appears across termination R1, while a sample of REFLECTED power appears across termination R5. The FORWARD and REFLECTED power RF samples from the directional coupler are detected by diodes CR1 and CR3. R/C filter networks are provided on both the FORWARD power and REFLECTED power signals and both are clamped to the +5 Volt rail through diodes CR2 and CR4 to prevent overdriving the A/D converter inputs of CPU chip, U5.

With voltages representing both FORWARD and REFLECTED power available to the CPU, it is possible to compute the VSWR continuously during the tuning process.

3.5 FREQUENCY COUNTER

The memory storage system in the SEA 1612C is based on the fact that the control computer senses what frequency is in use. This is accomplished by applying a prescaled sample of the RF signal to the the CPU timer input. The prescaler consists of U1A, U2 and U3. A sample of the RF signal is applied through a biased clamping network consisting of CR9, CR10, R17, R18, R19 and R20, to the input of CMOS schmitt trigger U1A. The shaped output signal is then divided by 2048 through cascaded counters U2 and U3.

The output from the counter train also serves as an interrupt generator for the CPU, acting as an "RF present" indicator.

IRQ signal consists of a logic "low" signal on pin 2 of U5 and may be derived from any of several sources.

1. The output from the frequency counter chain (U2, U3) is AC coupled to the gate of MOSFET amplifier Q2. The drain of Q2 is connected to pin 2 of U5. Thus, whenever the frequency counter is generating an output, an interrupt signal is present on the CPU IRQ pin.

2. The "DEMAND TUNE" input (P1, pin 3) is connected through a pair of cascaded inverters U1C and U1B and steering diode CR12 to the CPU IRQ pin. The inverters are biased in such a manner as to cause the output of U1B to remain "high" UNLESS the "DEMAND TUNE" line is grounded. When the "DEMAND TUNE" input is grounded, U1B will pull the CPU IRQ pin low through CR12, generating an input signal.

3. Beginning with PC board REVISION "C", an additional IRQ option has been added. It is possible to generate an interrupt via the PTT input line (P1, pin 5). The output of PTT inverter U1F can be diode ORed into the input of U1B by putting a shorting bar on the pins of JU4. With JU4 thus jumpered, an interrupt signal is generated whenever the PTT input line goes low. Note that if this option is selected, the PTT line must be connected to the system radiotelephone in order to sense the "key up" voltage on the radiotelephone PTT line. It is this open circuit voltage which prevents U1f from generating a continuous interrupt signal.

3.9 INFORMATION READ

The data sensors (previously described) are interfaced with the CPU through the A/D input ports, PC3, PC4 and PC5. Once the tune algorithm is running (following an interrupt request as outlined above and lacking any applicable prestored data) the program can access any desired variable by merely "looking" at the desired input port.

3.10 INFORMATION WRITE

When the CPU requires a change in the lumped RF tuner parameters, it writes the desired data into the series to parallel buffer. This is done by outputting the desired status of the network relays in a serial data stream from PB5 (SDO) on the CPU. Clocking is derived from PB7 (SCK). For example,

3.6 PHASE DETECTOR

T3, CR5, 6, 7 and 8 and the associated components form a phase detector which indicates the sign of any reactance associated with the antenna/tuner system as seen from the generator. Operationally, a line current sample is compared in phase with a voltage sample in a double balanced diode ring. Output polarity is NEGATIVE for a net CAPACITIVE reactance. The output of the phase detector is connected to an A/D input on the system CPU chip.

3.7 THE CONTROL COMPUTER

Actual antenna matching is implemented through a tuneup algorithm contained in the memory provided in the controller-computer system. The computer itself is designed around the HCMOS 68HC705P9P single chip CPU. This device was chosen for its' versatile instruction set and on-chip ROM, RAM and A/D converter. Control of the antenna tuner relays is done through U8, U9 and U10, together with relay drivers U11, U12 and U13. U8, U9 and U10 form a serial to parallel interface port. CLOCK and DATA signals are provided from CPU ports PB7 and PB5, respectively. In operation, data is transferred into the CPU under program control from the array of sensors. Essentially, the program monitors the status of the input sensors and, starting from a preset condition, manipulates the RF elements through its' control algorithm to achieve a correctly tuned condition. At the completion of the tuning algorithm, the computer generates a table in non-volatile memory which correlates the status of the various network relays with the applied RF frequency. This table is stored in EEPROM U4 and is used to provide the "learning" feature in the SEA 1612C. After storing and latching the network status, the CPU returns to the "STOP" mode and waits for another "TUNE REQUEST" condition.

3.8 INITIALIZATION AND FIREUP

Since any microcomputer generates RF noise while running, U5 is normally held in the "STOP" mode and requires an interrupt signal to start program implementation. The CPU

IRQ signal consists of a logic "low" signal on pin 2 of U5 and may be derived from any of several sources.

1. The output from the frequency counter chain (U2, U3) is AC coupled to the gate of MOSFET amplifier Q2. The drain of Q2 is connected to pin 2 of U5. Thus, whenever the frequency counter is generating an output, an interrupt signal is present on the CPU IRQ pin.

2. The "DEMAND TUNE" input (P1, pin 3) is connected through a pair of cascaded inverters U1C and U1B and steering diode CR12 to the CPU IRQ pin. The inverters are biased in such a manner as to cause the output of U1B to remain "high" UNLESS the "DEMAND TUNE" line is grounded. When the "DEMAND TUNE" input is grounded, U1B will pull the CPU IRQ pin low through CR12, generating an input signal.

3. Beginning with PC board REVISION "C", an additional IRQ option has been added. It is possible to generate an interrupt via the PTT input line (P1, pin 5). The output of PTT inverter U1F can be diode ORed into the input of U1B by putting a shorting bar on the pins of JU4. With JU4 thus jumpered, an interrupt signal is generated whenever the PTT input line goes low. Note that if this option is selected, the PTT line must be connected to the system radiotelephone in order to sense the "key up" voltage on the radiotelephone PTT line. It is this open circuit voltage which prevents U1f from generating a continuous interrupt signal.

3.9 INFORMATION READ

The data sensors (previously described) are interfaced with the CPU through the A/D input ports, PC3, PC4 and PC5. Once the tune algorithm is running (following an interrupt request as outlined above and lacking any applicable prestored data) the program can access any desired variable by merely "looking" at the desired input port.

3.10 INFORMATION WRITE

When the CPU requires a change in the lumped RF tuner parameters, it writes the desired data into the series to parallel buffer. This is done by outputting the desired status of the network relays in a serial data stream from PB5 (SDO) on the CPU. Clocking is derived from PB7 (SCK). For example,

it is desired at some point in the tuneup sequence to INCREASE the inductance by one binary increment. To accomplish this, the CPU examines the binary number representing the status of the L control relays, decrements that number by one and clocks that number one bit at a time into the series to parallel buffer.

3.11 THE PROGRAM

The control algorithm is contained in CPU ROM. The actual program consists of many subroutines and branch statements in "machine language" for the 68HC705P9P. This program is complex, proprietary and protected by Copyright. For these reasons, no detailed treatment of the program will be given here. A general understanding of the process may be had by examination of the key steps the program makes in determining the lumped constants required to tune a 25 foot antenna (for example) at a frequency of first 4 MHz and then 1.6 MHz. In the 4 MHz case, immediately after startup the program will first examine the EEPROM table for applicable data. In the event that no previously stored data is found, or that any such data is tested and found incorrect, the program will initiate a tuneup sequence. By examination of the phase detector the determination is made that the antenna is short (capacitive) at the drive frequency, and so series L is inserted until the phase detector indicates that the load is no longer capacitive. At this point the program measures the VSWR. It will generally be greater than 2:1 and if so, the program increments the input C while manipulating series L to simultaneously raise the input impedance and maintain a resistive match. This process is continued until a satisfactory VSWR is obtained. Following tuneup, the network data is stored against an address determined by the frequency measurement already made and stored. The program is then terminated. If, in the previous example, it is not possible to normalize the reactance of the antenna with the available supply of L (possible at 1.6 MHz), the program will increment the output C and search the L again, continuing in this fashion until the phase detector indicates that the load is resistive. It will then measure the VSWR and proceed as before. The difference is that now the network will be a PI network instead of the original L network. Additional subroutines are included in the program which set

various "breakpoints" in the allowable constants as a complex function of frequency. In fact, the overall "program" actually consists of a program SET which is designed to allow maximum flexibility while still maintaining high operating speed.

Another unique feature of the SEA 1612C is the "DUPLEX" operating mode. This mode is provided in order to allow the operator to eliminate the large loss in receiving sensitivity which can occur when the SEA 1612C (or any antenna tuner for that matter) is used in the 2-3 MHz spectrum. The sensitivity loss occurs as a result of the relatively narrow bandwidth of the matching network when used with short antennas. Remember that the tuner responds to TRANSMITTER frequencies on tuneup and so acts as a narrowband preselector filter at the transmitter frequency. Normally, this creates no problem, but in special cases, particularly when the antenna system is short, the ground system good, and the receiver frequency is far removed from the transmitter frequency, considerable loss in receiver sensitivity can result. The problem is especially acute when the wide split puts the receiver frequency on the "high side", since the tuning network is generally configured as a low pass filter. The "DUPLEX" mode makes use of a special control algorithm which, when energized, senses the RECEIVE mode and switches out all tuning elements. This connects the antenna directly to the input of the receiver and, while the receiver input will not be "matched" to the antenna, a substantial increase in overall sensitivity will generally result. When transmitter operation resumes, the SEA 1612C will revert to the previously stored tune data.

If it is desired to utilize the DUPLEX operating mode, contact the factory for information regarding the control requirements.

4. INSTALLATION PROCEDURE

4.1 MECHANICAL CONSIDERATIONS

The SEA 1612C requires only that a source of 13.6 VDC, an RF transmission line (RG-58/U up to 30 feet, RG-213/U over 30 feet) and a suitable antenna/ground system be attached. No bandswitch information, low power tune, or "handshake" is required to the RF generator, since the coupler tunes on voice signals. Power consumption is nominally less than 1 amp, allowing the use of light 3 to 5-conductor shielded cable for reasonable run lengths. (NOTE: The extra conductors in the power cable are to provide for an "ALL TUNED" indicator flag and/or the "TUNE LOCKOUT" and "DEMAND TUNE" feature(s) when desired.

Weatherdeck mounting is permitted for the SEA 1612C but years of marine experience indicate that inside mounting or even just splash-protected mounting is to be preferred, particularly in cold, damp environments. See Figure 1.3, "Outline and Mounting Dimensions", for details regarding the location of the mounting holes for the SEA 1612C. Although the SEA 1612C may be mounted in any attitude, care should be taken to insure that the location chosen is accessible for service and that the breathing vent hole (located on the rear of the molded case) is neither blocked or routinely submerged.

The base of the antenna should be connected to the high voltage feedthrough insulator on the top of the SEA 1612C weather housing. Note that this insulator is not designed to support heavy mechanical loads. If such loading is encountered, the use of a strain insulator is required.

The ground system should be connected to the 1/4 inch stainless steel stud protruding from the bottom of the weather housing. Connection to the ground system and the ground system itself are of extreme importance for a successful installation. Ground runs of over a few inches should be made from 4 inch wide copper strap or better. The actual ground system should be as good as possible and may consist of screening embedded in decks or roofs, coamings,

rails, stack shrouds, water and/or fuel tanks, etc. Ships with a non-conducting structure such as fiberglass require careful attention to detail to provide an adequate ground system. Please note that this attention to ground integrity is NOT unique to the SEA 1612C. ALL shipboard installations have the same requirements. The SEA 1612C autotune algorithm is capable of providing an adequate impedance match for an extremely wide variety of antenna/ground systems. This capability will insure proper operation of the system radiotelephone. It can NOT however insure that the antenna/ground system will radiate RF energy effectively. Such radiation efficiency is solely a function of the antenna and ground installation. A PROPER ANTENNA/GROUND INSTALLATION IS OF PARAMOUNT IMPORTANCE!

4.2 ELECTRICAL CONSIDERATIONS

Connector P1 on the antenna tuner printed circuit board provides the cable interconnect for power, shield ground, the "ALL TUNED" flag and when desired, the "DEMAND TUNE" and/or "TUNE LOCKOUT" features.

DC Power is connected to terminals 1 and 2 of P1. Pin 1 is the negative terminal and pin 2 is the positive terminal. The coupler runs off a nominal 13.6 volt source and the entire tuner is protected against reversed polarity connection by series diode CR15.

A remote "ALL TUNED" indicator can be connected to pin 4 of P1. This terminal is pulled to ground when the tuner has completed the antenna tuneup cycle. Radiotelephones like the SEA 222, SEA 322 and SEA 225 are designed to make direct use of the "ALL TUNED" flag line. Simply connect the "TND" terminal (P1, Pin 4) to the radiotelephone "TND" terminal.

The SEA 1612C "DEMAND TUNE" feature allows the operator to override the channel storage memory when desired. This is accomplished by momentarily grounding P1, Pin 3. If this feature is to be used at the radiotelephone, connect a wire from P1, Pin 3 through a momentary switch to ground.

When two or more radiotelephone systems are co-located, it is commonplace for a transmission on one system to upset

the antenna tuner setup on the other. This happens when energy from one antenna is absorbed by the other in sufficient quantity to "fool" the other antenna tuner into resetting. This condition can be alleviated by using the "TUNE LOCKOUT" feature.

To invoke the "TUNE LOCKOUT" feature of the SEA 1612C, connect P1, Pin 5 (PTT) to the PTT line in the associated radiotelephone through the interconnect cable. This connection will allow the SEA 1612C to sense the open circuit (KEY UP) voltage from the radiotelephone PTT line. This voltage is used to inhibit tuner operation. When the voltage is absent (KEY DOWN condition), the tuner operates normally. The SEA 1612C "TUNE LOCKOUT" port circuitry is compatible with open circuit voltages between +5 and +15 volts, DC. Port impedance is approximately 100K ohms.

4.3 ELECTRICAL CHECKOUT

After mechanical installation is completed, the SSB transmitter should be adjusted to the HIGHEST frequency desired, a directional wattmeter such as the BIRDtm Model 43 inserted into the transmission line, and the transmitter energized. Upon application of RF energy, the SEA 1612C should begin to tune, indicated by a general "clattering" of the PC mounted relays. If the antenna length and ground parameters are within range, a few syllables of speech should immediately cause the relay noise to cease, reflected power on the wattmeter to drop to a value consistent with a better than 2:1 VSWR and the PC mounted "TUNED" LED, CR14, to light. (If a remote "TUNED" indicator is provided, such as the "TND" annunciator on the SEA 225, this indicator should also light.)

The SSB transmitter should now be adjusted to the LOWEST desired frequency, and the speech test repeated. Again, the SEA 1612C should immediately sense the mismatch, enter the tune mode and retune the antenna system. The tune cycle will take somewhat longer at the lower frequencies, since the algorithm must search through more possible values of L and C to find an appropriate combination. A few seconds of speech should result in an "all tuned" indication. If the antenna parameters are within the specified range, and the

above tests have been performed successfully, the SEA 1612C installation and tuneup may be considered complete.

Note that, as received, the memory system in the SEA 1612C will most likely not contain prestored data appropriate to your installation. For this reason, the memory feature will likely NOT be impressive at first. To allow the SEA 1612C to "learn" your antennas' requirements, simply proceed from frequency to frequency, allowing the normal tuneup to take place. As more and more frequencies are "memorized" by the computer, it should be possible to return to a previously used frequency and discover that the computer immediately flashes the "ALL TUNED" flag, usually before the first syllable is completed. It should be further noted that the EEPROM memory system is capable of storing hundreds of individual frequency/relay combinations but that most of these combinations are actually used in the first 4 or 5 MHz of operating frequencies. This is done in order to provide better memory resolution at the lower frequencies where antenna systems are inherently narrowband. Very often, one or two memory positions will give adequate band coverage at frequencies in the higher marine bands.

5. TROUBLESHOOTING

5.1 COUPLER WILL NOT TUNE - NO RELAY ACTION

1. Apply +12 VDC to the antenna tuner and measure the DC voltages needed for operation:

A. +12 VDC on left hand side of U7. (NOTE: PC board is oriented with coaxial connector (J1) as the lower right hand corner.)

B. +5 VDC on right hand side of U7, Pins 1 and 28 of U5 and Pin 2 of U1.

2. The relays should initialize in the following way:

K0 thru K5 - open

K6 thru K15 - closed

K16 thru K25 - open

This will indicate that the CPU and the associated circuitry is probably working correctly. (Unless intermittent)

3. Individual relays may be tested by simply grounding the appropriate relay driver pin with a short jumper wire. (eg: To test K0, ground Pin 16 of U11. The jumper simulates the operation of the open-collector driver transistor between Pins 1 and 16 of U11.)

Individual relay drivers may be tested by using the jumper to connect the appropriate relay driver INPUT Pin to +5 VDC. (eg: To test the relay driver associated with K0, connect the jumper between U11, Pin 1 and +5 VDC.) NOTE: Integrated circuits U8, U9 and U10 should be removed when this test is performed. Otherwise, they may be damaged.

The serial-to-parallel shift register (U8, U9 and U10) I.C.s may be tested as follows:

Remove U5 from its socket. Jumper Pins 1 and 16 of U8. Also connect a jumper from Pin 2 of U8 and ground. When DC voltage is applied to the board, the relays will energize in a random pattern. To sequentially operate the relays, it is

possible to manually "clock" the relay driver circuitry. This is accomplished by applying a +5 volt pulse to Pin 13 of the U5 socket. (Using a short jumper connected to Pin 13 of U5, momentarily connect the jumper to the +5 volt rail and then to ground.) Each pulse will clock a DATA 0 into the serial-to-parallel relay driver, opening one relay per clock pulse. To reset the relays simply connect the jumper from Pin 2 of U8 to +5 VDC instead of ground. Once again, "clocking" Pin 13 of the U5 socket will sequentially close one relay per clock pulse. Note that the relays are always clocked sequentially, starting at K0 and proceeding through K25.

4. If step 3 indicates that the relay driver circuitry is functioning properly, the problem may be a defective CPU (U5). This must be tested by substitution. Replace the suspected part with a known good CPU.

5. In the event that a substitute I.C. does not solve the problem, check for bent pins on the socketed I.C.s.

6. Using a suitable oscilloscope, check the RF level present at Pin 13 of U1. (A level of approximately 8 V p-p should appear when an RF signal of 150 watts is connected to J1.)

7. The signal present on Pin 10 of U3 under the conditions described in Step 6 should be a 5 V p-p signal with a frequency 1/4 of that seen on Pin 13 of U1. (eg: Input frequency = 2048 KHz, Pin 10 of U3 = 512 KHz.)

8. The signal present on Pin 12 of U3 under the conditions described in Step 6 should be a 5 V p-p signal with a frequency 1/2048 of that seen on Pin 13 of U1. (eg: Input frequency = 2048 KHz, Pin 12 of U3 = 1 KHz.) Note: This same signal should be present at Pin 25 of U5.

5.2 RELAYS OPERATE BUT NO TUNE

1. Check the sensor diodes (CR1, CR3) for correct operation by using the diode test scale of a digital multimeter. Typical forward voltage drop will be approximately 0.57 VDC. Reverse direction reading varies with the meter used and which diode is under test. This is a function of in-circuit testing. If you have ANY concern about the reverse direction

reading, unsolder one lead of the diode under test. The reverse reading should then be open.

2. Connect a DC voltmeter between R15 and the ground rail. With no RF signal present, the voltmeter should read approximately +2.5 VDC.

Connect the RF output terminal to an appropriate antenna simulator and apply RF power to the coaxial input connector (J1). The relays should begin to operate by increasing the inductance (Relays K6 through K15 will open sequentially). The voltmeter connected to R15 should read less than +2.5 VDC when the antenna is capacitive (ie: shorter than 1/4 wavelength) and greater than +2.5 VDC when the antenna is inductive (ie: longer than 1/4 wavelength).

3. Check that Pin 2 of U5 is pulsed low when RF power is applied to J1. (You must have forward power present which will cause Pin 12 of U3 to output a square wave).

4. The most common problems encountered under "no tune" conditions have been: Bad diodes, defective (burned contacts) relays and broken or burnt wires on T1 and T2. The voltage winding on T2 may be checked by using an ohmmeter between the antenna terminal and the ground rail. A short circuit to ground indicates that the winding is good. The other transformer windings should also be tested between ground and the appropriate point in the circuit. NOTE: These components may be damaged by near-by lighting strikes.

5.3 COUPLER TUNES BUT NO MEMORY

1. Check for +5 VDC on Pin 8 of U4.

2. If normal voltage is present, suspect U4 or U5 as possibly damaged. Test by substitution.

5.4 TUNER WILL NOT DEMAND TUNE

1. Check that the "DEMAND TUNE" (DTN) line (P1, Pin 3) is at +5 VDC.

2. Wait approximately 1 second before pulling the "DEMAND TUNE" line low. The tuner must turn off the clock before it can acknowledge a second "DEMAND TUNE" signal. (This condition will occur 1 second after loss of forward power with the "DEMAND TUNE" line high.)

SECTION 6

**SCHEMATICS AND
CIRCUIT
BOARD DETAILS**

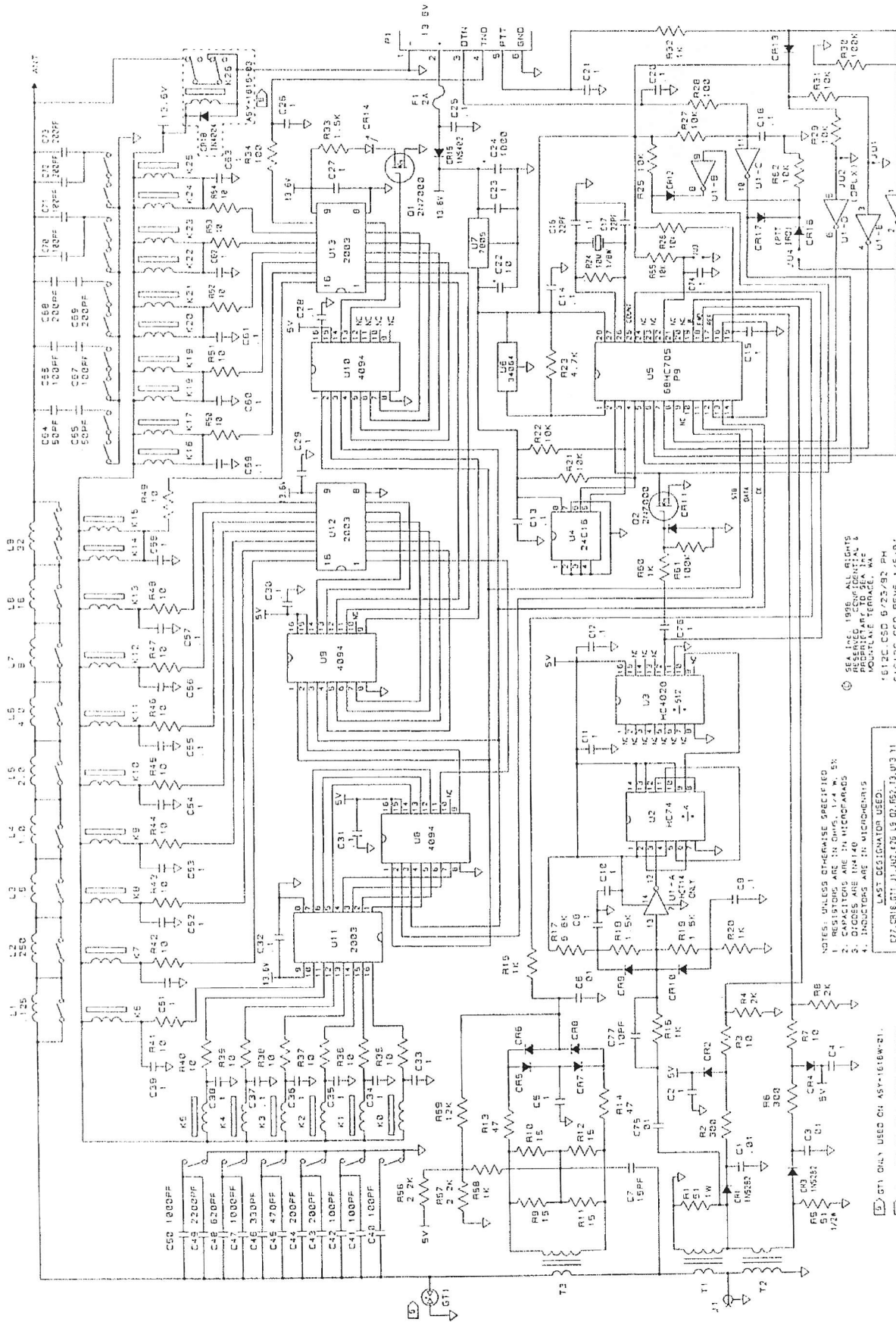

SEA 1612C
FIGURE 6.1

ANTENNA TUNER SCHEMATIC
ASY-1616-01 REV C

NOTES: UNLESS OTHERWISE SPECIFIED
RESISTORS ARE IN OHMS, 1/4 W, 5%
CAPACITORS ARE IN MICROFARADS
DIODES ARE 1N4140
INDUCTORS ARE IN MICROHENRYS

SEA-1616-01, J1, J2, J3, J4, J5, J6, J7, J8, J9, J10, J11, J12, J13, J14, J15, J16, J17, J18, J19, J20, J21, J22, J23, J24, J25, J26, J27, J28, J29, J30, J31, J32, J33, J34, J35, J36, J37, J38, J39, J40, J41, J42, J43, J44, J45, J46, J47, J48, J49, J50, J51, J52, J53, J54, J55, J56, J57, J58, J59, J60, J61, J62, J63, J64, J65, J66, J67, J68, J69, J70, J71, J72, J73, J74, J75, J76, J77, J78, J79, J80, J81, J82, J83, J84, J85, J86, J87, J88, J89, J90, J91, J92, J93, J94, J95, J96, J97, J98, J99, J100

U1, U2, U3, U4, U5, U6, U7, U8, U9, U10, U11, U12, U13, U14, U15, U16, U17, U18, U19, U20, U21, U22, U23, U24, U25, U26, U27, U28, U29, U30, U31, U32, U33, U34, U35, U36, U37, U38, U39, U40, U41, U42, U43, U44, U45, U46, U47, U48, U49, U50, U51, U52, U53, U54, U55, U56, U57, U58, U59, U60, U61, U62, U63, U64, U65, U66, U67, U68, U69, U70, U71, U72, U73, U74, U75, U76, U77, U78, U79, U80, U81, U82, U83, U84, U85, U86, U87, U88, U89, U90, U91, U92, U93, U94, U95, U96, U97, U98, U99, U100

DESIGNATORS NOT USED: _____

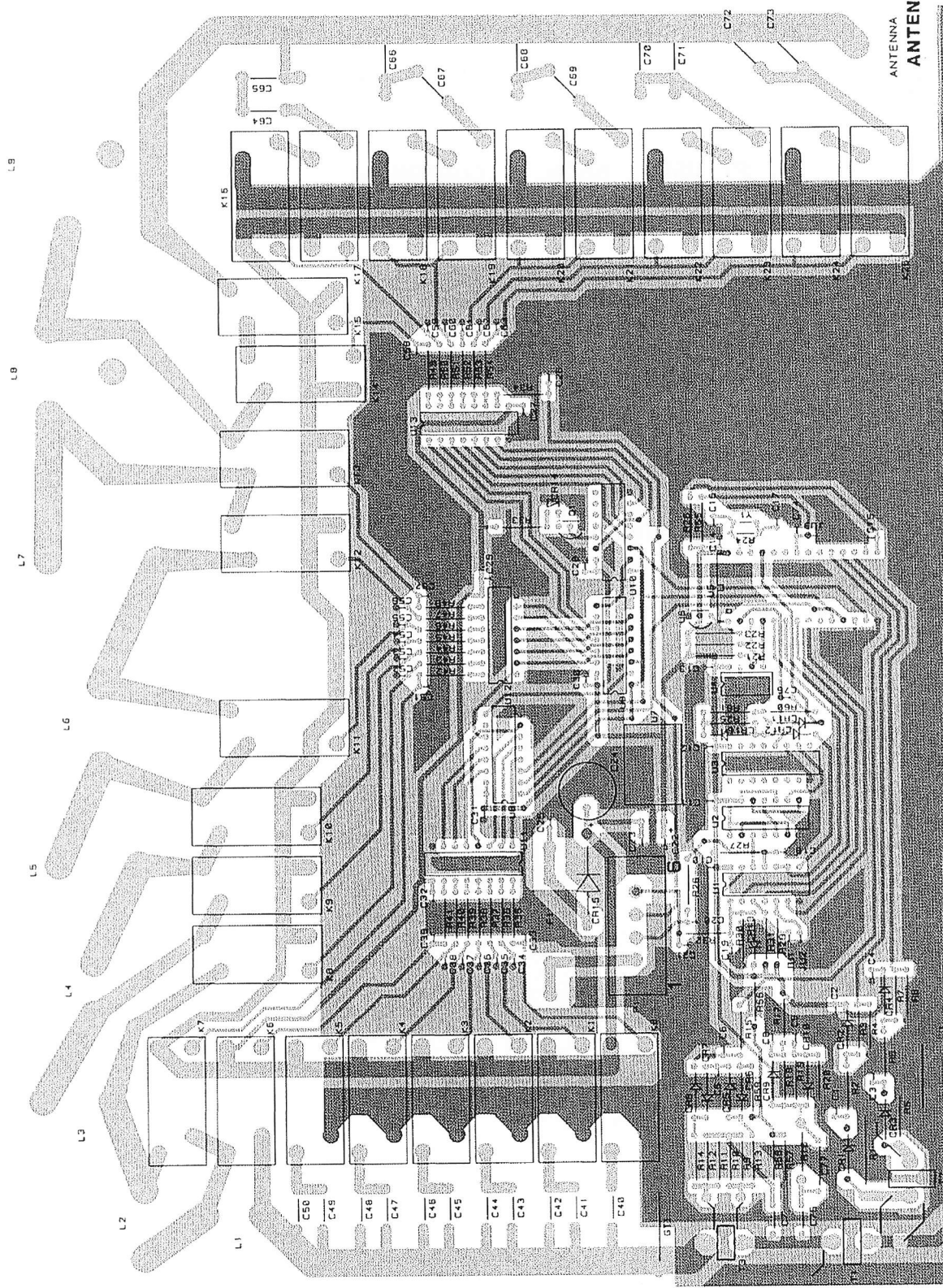

ANTENNA
ANTENNA TUNER BOARD
SEA 1612C
FIGURE 6.2

1	2	3	4	5	6	7	8	9	10	11	12	13	14	15	16	17	18	19	20	21	22	23	24	25	26	27	28	29	30	31	32	33	34	35	36	37	38	39	40	41	42	43	44	45	46	47	48	49	50	51	52	53	54	55	56	57	58	59	60	61	62	63	64	65	66	67	68	69	70	71	72	73	74	75	76	77	78	79	80	81	82	83	84	85	86	87	88	89	90	91	92	93	94	95	96	97	98	99	100
---	---	---	---	---	---	---	---	---	----	----	----	----	----	----	----	----	----	----	----	----	----	----	----	----	----	----	----	----	----	----	----	----	----	----	----	----	----	----	----	----	----	----	----	----	----	----	----	----	----	----	----	----	----	----	----	----	----	----	----	----	----	----	----	----	----	----	----	----	----	----	----	----	----	----	----	----	----	----	----	----	----	----	----	----	----	----	----	----	----	----	----	----	----	----	----	----	----	----	-----

© 1966, INC. OF DELAWARE - 1953 PCB-16-16-01-REV-A MADE IN USA

SEA INC.
SINGLE LEVEL BILL

PAGE: 1
11/18/1996

PARENT: 1612C DESC: AUTO ANTENNA TUNER
RV: UM: EA RUN LT: 1 FIXED LT: 5

PT USE SEQN COMPONENT

PT USE	SEQN	COMPONENT	DESCRIPTION	C T	Q T	M U	L B	M T
000	000	SNO-0009-002	SN# LABEL	D	5	I	EA	M N
BOXNG	000	KIT-1612-99	HARDWARE KIT	N	1	I	EA	M N
BOXNG	000	BOX-1612-004	PAD, 11X17 CARDBOARD	N	2	I	EA	B N
BOXNG	000	BOX-1612-001	COUPLER SHIPPING BOX	N	1	I	EA	B N
BOXNG	000	BOX-1612-003	REVERSIBLE INSERT 1612B/1	N	1	I	EA	B N
BOXNG	000	MAN-1612C	SEA 1612C MANUAL	N	1	I	EA	S N
BOXNG	000	HAR-0029-004	COR-PAK BREATHABLE POUCHE	N	1	I	EA	B N
FINAL	000	ASY-1616-01	1612C ANTENNA TUNER	N	1	I	EA	M N
FINAL	000	ASY-1600-01	COUPLER BOX	N	1	I	EA	M N
FINAL	000	LBL-1010-001	DECAL, SEA FOR COUPLER	N	1	I	EA	B N
FINAL	000	LBL-1612-002	CAUTION LABEL	N	1	I	EA	B N
LAB	000	LAB[R]ASSY	LABOR, ASSEMBLY	R	2.46	I	HR	M N
LAB	000	LAB[R]INSP	LABOR, INSPECTION	R	.2	I	HR	M N
LAB	000	LAB[R]TEST	LABOR, TEST	R	.1	I	HR	M N
REV	000	ECN 5911	ASY-1600-01 01/17/95	D	1	O	EA	B N
TEST2	000	OPS-1612C-U5	OPERATING SYS 1612C PROG	N	1	I	EA	M N

*** END OF REPORT ***

SEA INC.
SINGLE LEVEL BILL OF MATERIAL

PARENT: ASY-1616-01

DESC: 1612C ANTENNA TUNER

UM: EA

MB: M

REV:

EFFECTIVITY DATE: 092195

EFFECTIVE REV:

PT	USE SEQN COMPONENT	DESCRIPTION	M C Q REV B T T IN OUT	QUANTITY UM	EFFECTIVITY IN OUT	LTOS	SCRAP PCNT
STUFF 000	ASY-1061-L2	INDUCTOR, 1.0UH L4	B N I	1 EA	011595 123179	0	0.0
STUFF 000	ASY-1061-L3	INDUCTOR, 2.0UH L5	B N I	1 EA	011595 123179	0	0.0
STUFF 000	ASY-1061-L4	INDUCTOR, 4.0UH L6	B N I	1 EA	011595 123179	0	0.0
STUFF 000	ASY-1061-L5	INDUCTOR, 8UH L7	B N I	1 EA	011595 123179	0	0.0
STUFF 000	ASY-1061-L7	INDUCTOR, 32UH L9	S N I	1 EA	011595 123179	0	0.0
STUFF 000	ASY-1612-10	45% UHF CONN ASSY J1	M P I	1 EA	011595 123179	0	0.0
STUFF 000	ASY-1612-L6	INDUCTOR, 16UH L8	S N I	1 EA	011595 123179	0	0.0
POST 000	ASY-1612-T3	TRANSFORMER PHASE T3	M P I	1 EA	011595 123179	0	0.0
STUFF 000	ASY-1630-L1	AIR INDUCTOR, .125UH 3 TU L1	B N I	1 EA	011595 123179	0	0.0
STUFF 000	ASY-1630-L2	AIR INDUCTOR, .250UH 5 TU L2	B N I	1 EA	011595 123179	0	0.0
STUFF 000	ASY-1630-L3	AIR IND, .50UH 8 TURNS L3	B N I	1 EA	011595 123179	0	0.0
POST 000	ASY-1630-71	XFORMER, 1630/330 POWER DE T1, T2	M P I	2 EA	011595 123179	0	0.0
STUFF 000	CAP-0003-001	CAPACITOR DM19 100PF C40, C41, C42	B N I	3 EA	011595 123179	0	0.0

SEA INC.
SINGLE LEVEL BILL OF MATERIAL

PARENT: ASY-1616-01

DESC: 1612C ANTENNA TUNER

UM: EA

MB: M

REV:

EFFECTIVITY DATE: 092195

EFFECTIVE REV:

PT	USE SEQN COMPONENT	DESCRIPTION	M C Q REV	B T T IN OUT	QUANTITY UM	EFFECTIVITY IN OUT	LTOS	SCRAP PCNT
STUFF 000	CAP-0003-003	CAPACITOR DM19 330PF C46	B N I		1 EA	011595 123179	0	0.0
STUFF 000	CAP-0003-004	CAPACITOR DM19 470PF C45	B N I		1 EA	011595 123179	0	0.0
STUFF 000	CAP-0003-006	CAPACITOR DM19 1000PF C47,C50	B N I		2 EA	011595 123179	0	0.0
STUFF 000	CAP-0003-010	CAPACITOR DM19 2200PF C49	B N I		1 EA	011595 123179	0	0.0
STUFF 000	CAP-0003-014	CAPACITOR DM19 620PF C48	B N I		1 EA	011595 123179	0	0.0
STUFF 000	CAP-0003-021	CAPACITOR DM19 200PF C43,C44	B N I		2 EA	011595 123179	0	0.0
STUFF 000	CAP-0013-001	CAPACITOR MONO .1UF C2,C4,C5,C8,C9,C10,C11,C12,C13,C14,C15,C18,C19,C20,C21,C23,C 25,C26,C27,C28,C29,C30,C31,C32,C33,C34,C35,C36,C37,C38,C39,C 51,C52,C53,C54,C55,C56,C57,C58,C59,C60,C61,C62,C63,C74,C76	B N I		46 EA	011595 123179	0	0.0
STUFF 000	CAP-0013-003	CAPACITOR MONO .01UF 100V C1,C3,C6,C75	B N I		4 EA	011595 123179	0	0.0
STUFF 000	CAP-6031-005	CAPACITOR TANT 10UF 16V C22	B N I		1 EA	011595 123179	0	0.0
STUFF 000	CAP-0037-102	CAP, ELECT. 1000UF RAD .2LS C24	B N I		1 EA	011595	0	0.0
STUFF 000	CAP-0050-050	CAPACITOR, 50PF 5KV RMC C64,C65	B N I		2 EA	011595 123179	0	0.0
STUFF 000	CAP-0050-100	CAP, 100PF 5KV .5LS C66,C67,C70,C71	B N I		4 EA	011595 123179	0	0.0
STUFF 000	CAP-0050-200	CAP, 200PF 5KV RMC .5LS C68,C69,C72,C73	B N I		4 EA	011595 123179	0	0.0

SEA INC.
SINGLE LEVEL BILL OF MATERIAL

PARENT: ASY-1616-01

DESC: 1612C ANTENNA TUNER

UM: EA

MB: M

REV:

EFFECTIVITY DATE: 092195

EFFECTIVE REV:

PT	USE SEQ# COMPONENT	DESCRIPTION	M C Q REV	B T T IN OUT	QUANTITY UM	EFFECTIVITY	SCRAP
						IN OUT	LTOS PCNT
STUFF 000	CON-0240-020	2 PIN SINGLE ROW HEADER J01, J02, J04	B N I		3 EA	011595 123179	0 0.0
STUFF 000	CP-0001-003-32B	.1 LS, 22PF C16, C17	M N I		2 EA	011595	0 0.0
STUFF 000	CP-0002-022-02A	.45 LS, 10PF C77	M N I		1 EA	011595	0 0.0
STUFF 000	CP-0007-003-10B	.25LS, 15PF DM15 C7	M N I		1 EA	011595	0 0.0
POST 000	CRY-0011-002	COLOR BURST 3.579545 HC/18 Y1	B N I		1 EA	011595 123179	0 0.0
POST 000	FUS-0002-002	FUSE, 2A 125V F1	B N I		1 EA	011595 123179	0 0.0
STUFF 000	FUS-0007-003	FUSE CLIP, PC MOUNT W/O E	B N I		2 EA	011595 123179	0 0.0
STUFF 000	HAR-0036-001	WSHR NY SHLDR .375X.6X.09	B N I		4 EA	011595 123179	0 0.0
STUFF 000	HAR-0043-001	WASHER, FLAT .050/1.05/.25	B N I		4 EA	011595 123179	0 0.0
LAB 000	LAB[R]ASSY	LABOR, ASSEMBLY	M R I		1.70 HR	051995	0 0.0
LAB 000	LAB[R]TEST	LABOR, TEST	M R I		0.33 HR	050495	0 0.0
000 000	PCB-1616-01	MAINBOARD PCB, SEA 1612C	B N I		1 EA	011595	0 0.0
STUFF 000	REL-0007-007	D/P BASE REL W/ CLEAR COV K1, K2, K3, K4, K5, K6, K7, K8, K9, K10, K11, K12, K13, K14, K15, K16, K17, K18, K19, K20, K21, K22, K23, K24, K25, K0	B N I		26 EA	011595 123179	0 0.0
STUFF 000	RES-0001-100	RESISTOR 10 1/4W R35, R36, R37, R38, R39, R40, R41, R42, R43, R44, R45, R46, R47, R48, R49, R50, R51, R52, R53, R54, R3, R7	B N I		22 EA	011595 123179	0 0.0
STUFF 000	RES-0001-101	RESISTOR 100 1/4W R28, R34	B N I		2 EA	011595 123179	0 0.0
STUFF 000	RES-0001-102	RESISTOR 1K 1/4W R15, R16, R20, R32, R58, R60	B N I		6 EA	011595 123179	0 0.0
STUFF 000	RES-0001-103	RESISTOR 10K 1/4W R21, R22, R25, R26, R27, R29, R31, R55, R62	B N I		9 EA	011595 123179	0 0.0

SEA INC.
SINGLE LEVEL BILL OF MATERIAL

PARENT: ASY-1616-01

DESC: 1612C ANTENNA TUNER

UM: EA

MB: M

REV:

EFFECTIVITY DATE: 092195

EFFECTIVE REV:

PT	USE SEQN COMPONENT	DESCRIPTION	M C Q REV	B T T IN OUT	QUANTITY UM	EFFECTIVITY	IS	OUT	LTOS	SCRAP	PCNT
STUFF 000	RES-0001-104	RESISTOR 100K 1/4W R30,R61	B N I		2 EA	011595	123179		0	0.0	
STUFF 000	RES-0001-123	RESISTOR 12K 1/4W R59	B N I		1 EA	011595	123179		0	0.0	
STUFF 000	RES-0001-150	RESISTOR 15 1/4W R9,R10,R11,R12	B N I		4 EA	011595	123179		0	0.0	
STUFF 000	RES-0001-152	RESISTOR 1.5K 1/4W R18,R19,R33	B N I		3 EA	011595	123179		0	0.0	
STUFF 000	RES-0001-202	RESISTOR 2K 1/4W R4,R8	B N I		2 EA	011595	123179		0	0.0	
STUFF 000	RES-0001-222	RESISTOR 2.2K 1/4W R56,R57	B N I		2 EA	011595	123179		0	0.0	
STUFF 000	RES-0001-301	RESISTOR 300 1/4W R2,R6	B N I		2 EA	011595	123179		0	0.0	
STUFF 000	RES-0001-470	RESISTOR 47 1/4W R13,R14	B N I		2 EA	011595	123179		0	0.0	
STUFF 000	RES-0001-472	RESISTOR 4.7K 1/4W R23	B N I		1 EA	011595	123179		0	0.0	
STUFF 000	RES-0001-562	RESISTOR 5.6K 1/4W R17	B N I		1 EA	011595	123179		0	0.0	
STUFF 000	RES-0002-510	RESISTOR, 51 OHM 1/2 W 5% R5	B N I		1 EA	011595	123179		0	0.0	
STUFF 000	RES-0006-510	RES, 51 OHM, 1 WATT R1	B N I		1 EA	011595	123179		0	0.0	
STUFF 000	RES-0010-106	RESISTOR, 10MEG OHM R24	B N I		1 EA	011595	123179		0	0.0	
STUFF 000	SEM-0021-006	2N7000 MOSFET SWITCH (RED Q1,Q2	B N I		2 EA	011595	123179		0	0.0	

SEA INC.
SINGLE LEVEL BILL OF MATERIAL

PARENT: ASY-1616-01

DESC: 1612C ANTENNA TUNER

UM: EA

MB: M

REV:

EFFECTIVITY DATE: 092195

EFFECTIVE REV:

PT	USE SEQ# COMPONENT	DESCRIPTION	M C Q REV	B T I IN OUT	QUANTITY UM	EFFECTIVITY	IN	OUT	LTOS	SCRAP	PCNT
STUFF 000	SEM-0084-001	LED, RED, T1 CR14	B N I		1 EA	011595	123179		0	0.0	
STUFF 000	SEM-0089-001	1N5402 DIODE 3A RECTIFIER CR15	B N I		1 EA	011595	123179		0	0.0	
STUFF 000	SEM-0098-002	1N5282 ULTRA FAST DIODE, CR1,CR3	B N I		2 EA	011595	123179		0	0.0	
STUFF 000	SEM-0109-001	7805 VOLTAGE REG, 5V U7	B N I		1 EA	011595	123179		0	0.0	
STUFF 000	SEM-0140-094	4094 CMOS SHIFT/STORE REG U8,U9	B N I		2 EA	011595	123179		0	0.0	
TEST2 000	SEM-0140-094	4094 CMOS SHIFT/STORE REG U10	B N I		1 EA	011595	123179		0	0.0	
STUFF 000	SEM-0143-074	74HC74 CMOS DUAL D FLIP-F	B N I		1 EA	011595	123179		0	0.0	
STUFF 000	SEM-0143-402	74HC402 CMOS BINARY RIPP U3	B N I		1 EA	011595	123179		0	0.0	
STUFF 000	SEM-0144-014	74HCT14 HEX SCHMIT TRIG U1	B N I		1 EA	011595	123179		0	0.0	
STUFF 000	SEM-0151-003	1413P CMOS DARL TRANS ARR U11,U12,U13	B N I		3 EA	011595	123179		0	0.0	
POST 000	SEM-0187-002	16K-BIT SERIAL E2 PROM U4	B N I		1 EA	011595	123179		0	0.0	
STUFF 000	SEM-0193-001	MC34064P-5 TO-92 RESET GE U6	B N I		1 EA	011595	123179		0	0.0	
STUFF 000	SY-0076-001-02A	.45 LS, 1N4148 CR2,CR4,CR5,CR6,CR7,CR8,CR9,CR10,CR11,CR12,CR13,CR16,CR17	M N I		13 EA	011595	123179		0	0.0	
STUFF 000	SOC-0002-008	IC SOCKET, 8 PIN DIP U4SOC	B N I		1 EA	011595	123179		0	0.0	
STUFF 000	SOC-0002-016	IC SOCKET, 16 PIN DIP U10SO	B N I		1 EA	011595	123179		0	0.0	

SEA INC.
SINGLE LEVEL BILL OF MATERIAL

PARENT: ASY-1616-01

DESC: 1612C ANTENNA TUNER

UM: EA

MB: M

REV:

EFFECTIVITY DATE: 092195

EFFECTIVE REV:

PT	USE SEQN COMPONENT	DESCRIPTION	M C Q REV	B T T IN OUT	QUANTITY UM	EFFECTIVITY	SCRAP
						IN OUT LTOS	PCNT
	STUFF 000 SOC-0004-028	IC SOCKET, 28 PIN DIP U5SOC	B N I		1 EA	011595 123179	0 0.0
	STUFF 000 TER-0026-002	TERMINAL 3 POS P1	B N I		2 EA	011595 123179	0 0.0

* * * * * END OF REPORT * * * * *

SEA INC.
SINGLE LEVEL BILL

PAGE: 1
07/19/2001

PARENT: 1612W
RV:

UM: EA

DESC: 1612C TUNER WITH SPARK GAP
RUN LT: 1 FIXED LT: 5

PT USE SEQN COMPONENT
STARTING:

PT USE	SEQN	COMPONENT	C T	QUANTITY	Q T	M UM	L B	EFFECTIVITY IN	OUT	LT OFFSET	SCR PCT
BOXNG	000	BOX-1612-004 PAD,11X17 CARDBOARD	N	2	I	EA	B N	011595 123179		0	0.0
BOXNG	000	BOX-1612-001 COUPLER SHIPPING BOX	N	1	I	EA	B N	011595 123179		0	0.0
BOXNG	000	BOX-1612-003 REVERSIBLE INSERT 1612B/1	N	1	I	EA	B N	011595 123179		0	0.0
BOXNG	000	MAN-1612C SEA 1612C MAINTENANCE MANUAL	N	1	I	EA	S N	011595 123179		0	0.0
BOXNG	000	KIT-1612W-99 HARDWARE KIT 1612W/1612WX	N	1	I	EA	M N	011595 123179		1	0.0
FINAL	000	LBL-1010-001 DECAL, SEA FOR COUPLER	N	1	I	EA	B N	011595 123179		0	0.0
FINAL	000	ASY-1612W ANTENNA TUNER	N	1	I	EA	M N	011595 123179		0	0.0
LAB	000	LAB[R]ASSY LABOR, ASSEMBLY	R	.13359788	I	HR	M N	032495 123179		0	0.0

*** END OF REPORT ***

SEA INC.
SINGLE LEVEL BILL

PAGE: 1
07/19/2001

PARENT: PST-1612W DESC: ANTENNA TUNER
RV: UM: EA RUN LT: 1 FIXED LT: 0

PT USE	SEQN	COMPONENT	PT USE	SEQN	COMPONENT	Q T	U M	B	L T	EFFECTIVITY IN	OUT	LT OFFSET	SCR PCT
000	000	ASY-1616W-01	N			1	I	EA	M	N	011595	123179	0 0.0
		1612W COUPLER BOARD (TESTED)											
000	000	ASY-1600-01	N			1	I	EA	M	N	011595	123179	0 0.0
		COUPLER BOX											
000	000	LBL-1612-002	N			1	I	EA	B	N	011595	123179	0 0.0
		LABEL, CAUTION											
LAB	000	LAB[R]ASSY	R			.1163522	I	HR	M	N	032495	123179	0 0.0
		LABOR, ASSEMBLY											
REF	000	SNO-0009-002	X			5	I	EA	M	N	011595	123179	0 0.0
		SN# LABEL											

*** END OF REPORT ***

SEA INC.
SINGLE LEVEL BILL

PAGE: 1
07/19/2001

PARENT: 1612WX DESC: 1612W TUNER W/ANT. GROUNDING RELAY
RV: UM: EA RUN LT: 1 FIXED LT: 5

PT USE	SEQN	COMPONENT	C T	QUANTITY	Q T	M U M	L B T	EFFECTIVITY IN	OUT	LT OFFSET	SCR PCT
BOXNG	000	BOX-1612-004	N	2	I	EA	B N	011595	123179	0	0.0
		PAD, 11X17 CARDBOARD									
BOXNG	000	BOX-1612-001	N	1	I	EA	B N	011595	123179	0	0.0
		COUPLER SHIPPING BOX									
BOXNG	000	BOX-1612-003	N	1	I	EA	B N	011595	123179	0	0.0
		REVERSIBLE INSERT 1612B/1									
BOXNG	000	MAN-1612C	N	1	I	EA	S N	011595	123179	0	0.0
		SEA 1612C MAINTENANCE MANUAL									
BOXNG	000	KIT-1612W-99	N	1	I	EA	M N	011595	123179	1	0.0
		HARDWARE KIT 1612W/1612WX									
FINAL	000	LBL-1010-001	N	1	I	EA	B N	011595	123179	0	0.0
		DECAL, SEA FOR COUPLER									
FINAL	000	ASY-1612WX	N	1	I	EA	M N	011595	123179	0	0.0
		ANTENNA TUNER WITH RELAY (TESTED)									
LAB	000	LAB[R]ASSY	R	.13359788	I	HR	M N	032495	123179	0	0.0
		LABOR, ASSEMBLY									

*** END OF REPORT ***

SEA INC.
SINGLE LEVEL BILL

PAGE: 1
07/19/2001

PARENT: PST-1612WX
RV: UM: EA

DESC: ANTENNA TUNER
RUN LT: 1 FIXED LT: 0

PT USE	SEQN	COMPONENT	PT USE	SEQN	COMPONENT	Q T	M U M	L B T	EFFECTIVITY IN	OUT	LT OFFSET	SCR PCT
000	000	ASY-1616W-01 1612W COUPLER BOARD (TESTED)	N			1	I	EA M N	011595	123179	0	0.0
000	000	ASY-1600-01 COUPLER BOX	N			1	I	EA M N	011595	123179	0	0.0
000	000	LBL-1612-002 LABEL, CAUTION	N			1	I	EA B N	011595	123179	0	0.0
000	000	ASY-1616-03 RF RELAY ASSEMBLY	N			1	I	EA M N	010100	123179	0	0.0
LAB	000	LAB[R]ASSY LABOR, ASSEMBLY	R			.1163522	I	HR M N	032495	123179	0	0.0
REF	000	SNO-0009-002 SN# LABEL	X			5	I	EA M N	011595	123179	0	0.0

*** END OF REPORT ***

SEA INC.
SINGLE LEVEL BILL

PAGE: 1
07/19/2001

PARENT: ASY-1616-03 DESC: RF RELAY ASSEMBLY
RV: UM: EA RUN LT: 5 FIXED LT: 0

PT USE	SEQN	COMPONENT	C T	QUANTITY	Q T	M U M	L B T	EFFECTIVITY IN	OUT	LT OFFSET	SCR PCT
000	000	HAR-0600-004	X	1	I	EA	B N	053000	123179	0	0.0
		LUG, GROUND, #6	SS								
000	000	HAR-1000-004	X	1	I	EA	B N	053000	123179	0	0.0
		SOLDER LUG #10 BRASS									
000	000	REL-0005-002	N	1	I	EA	B N	053000	123179	0	0.0
		DPDT 12V RF RATED RELAY									
000	000	SEM-0087-001	N	1	I	EA	B N	053000	123179	0	0.0
		1N4004 DIODE GP RECTIFIER									
000	000	WIR-0008-000	X	.42	I	FT	B N	053000	123179	0	0.0
		WIRE, #16, HOOK-UP, BLACK									
000	000	WIR-0009-000	X	.125	I	FT	B N	053000	123179	0	0.0
		WIRE, #20, STRANDED, HOOK-UP, BLACK									
000	000	WIR-0009-200	X	.75	I	FT	B N	053000	123179	0	0.0
		WIRE, #20, STRANDED, HOOK-UP, RED									
000	000	WIR-0011-016	X	.084	I	FT	B N	053000	123179	0	0.0
		WIRE, #16, BUSS									
000	000	WIR-0024-020	X	.117	I	FT	B N	053000	123179	0	0.0
		TUBING, #20, SLEEVING, TEFLON									

*** END OF REPORT ***